

## PRODUCT DATASHEET

### ENDURA Classic Post 55cm E27

ENDURA® CLASSIC POST | Stainless steel luminaires with glass diffuser



#### Areas of application

- Outdoor use (IP44)
- Building facades
- Entrance lighting
- Patios, balconies
- Pathway lighting
- Driveways

#### Product benefits

- High flexibility in the choice of the light source thanks to E27 socket
- Easy and quick installation

#### Product features

- Stainless steel housing
- Diffuser made of clear glass with hammer finish
- Available with and without motion sensor
- Available as wall and bollard luminaires
- Suitable for smart applications thanks to compatibility with SMART+ lamps



**TECHNICAL DATA**

**Electrical data**

Nominal voltage	220...240 V
Mains frequency	50...60 Hz
Protection class	I
Operating mode	Mains voltage

**Dimensions & Weight**

Diameter	127.00 mm
Height	550.00 mm
Product weight	1300.00 g

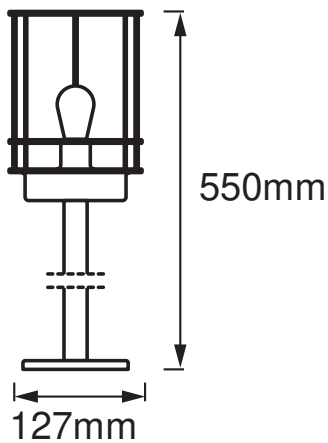

ENDURA CLASSIC POST 55CM  
E27 ST

**Materials & Colors**

Product color	Steel
Housing color	Steel
Body material	Stainless steel
Mercury content	0.0 mg

**Application & Mounting**

Ambient temperature range	-20...+40 °C
Temperature range at storage	-20...+85 °C
Type of connection	Screw terminal

Type of protection	IP44
Dimmable	No
Mounting type	Standing
Application environment	Outdoor
With light source	No
Replaceable light source	No
Holder designation	E27

### Certificates & Standards

Standards	CE / UKCA / EAC
-----------	-----------------

### Additional product data

Product remark	Maximum bulb wattage: 60 W
Number of illuminants	1



### EQUIPMENT / ACCESSORIES

- Complete mounting and connecting accessories included
- No light sources included

### Safety advice

- All electrical connections must be made by a qualified person.
- Caution, risk of electric shock.
- Product in protection class I. All electrically conductive, metallic housing parts that can absorb voltage during operation or during maintenance in the event of a fault must be continuously connected to the protective earthing conductor.

### DOWNLOAD DATA

	Documents and certificates	Document name
	User instruction / safety instructions	ENDURA CLASSIC POST
	Legal information	Safety insert G11219578
	Declarations of conformity	CE Declaration Endura Classic Post

### LOGISTICAL DATA

Product code	Packaging unit (Pieces/Unit)	Dimensions (length x width x height)	Gross weight	Volume
4099854452239	Folding box 1	154 mm x 154 mm x 576 mm	1705.00 g	13.66 dm <sup>3</sup>
4099854452246	Shipping box 4	589 mm x 322 mm x 326 mm	6820.00 g	61.83 dm <sup>3</sup>

The mentioned product code describes the smallest quantity unit which can be ordered. One shipping unit can contain one or more single products. When placing an order, for the quantity please enter single or multiples of a shipping unit.

---

## DISCLAIMER

Subject to change without notice. Errors and omission excepted. Always make sure to use the most recent release.